

PLANETARY MIXER (STANDARD) :



Description:

Intimate blending of different materials of different consistencies, viscosities, densities, shapes, proportion liquid / liquid,/ solid/solid is achieved effectively by use of planetary mixers.

1. Compact design of machine takes up minimum floor space.
2. Beater arms are available in a range of designs to achieve optimum out put for different types of materials.

Special Features:

- Product bowl mounted on castor wheels for easy portability, washing and transporting mixed materials.
- Choice of different designs of beaters to suit particular mixing requirements for a wide variety of materials.
- Flameproof construction optional.
- Higher capacity 750 L and 1000L models with auxiliary beaters.
- Motorized drive assembly for lifting and lowering.
- Needs comparatively smaller area for installation.
- Electrical control panel with back up fuses and indicator lamps for easy process control.
- Contact parts of S.S. 316 quality material. S.S 304 construction optional.
- Proper selection of Planetary and beater RPMs for different products.

Technical Data:

Models	PLM 200	PLM 350	PLM 500
Capacity	220L	380L	520L
Dimensions in mm	1100x1900x2100	1100x2200x2450	1400x2750x2500

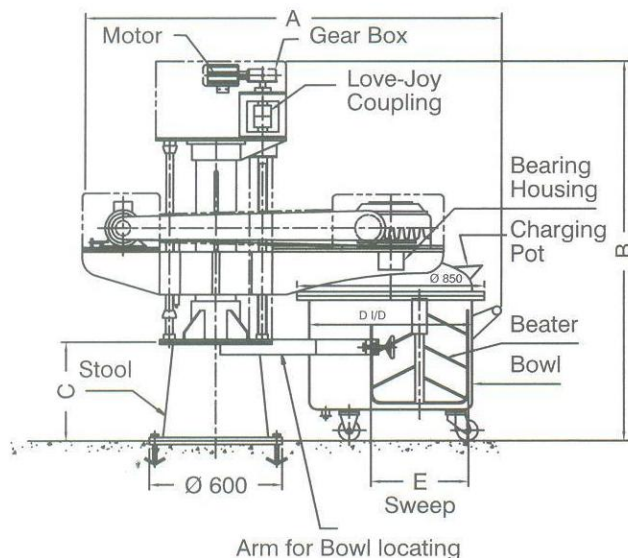

Note : Images Shown here are illustrative. As the design & manufacturing of Machines are subject to improvement, the product supplied will be as per our Techno-Commercial offer.